

Çok Önceleri

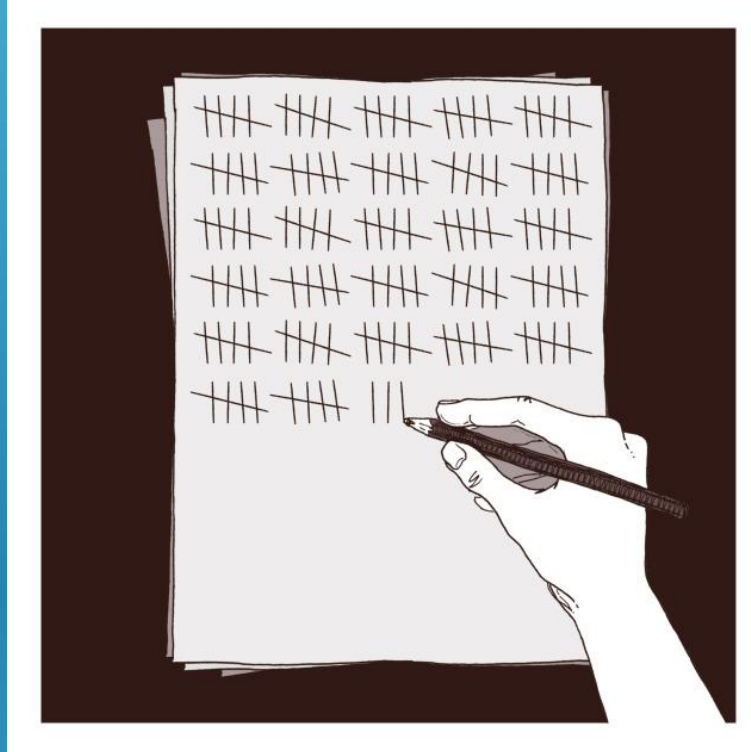

Çizgi - MÖ

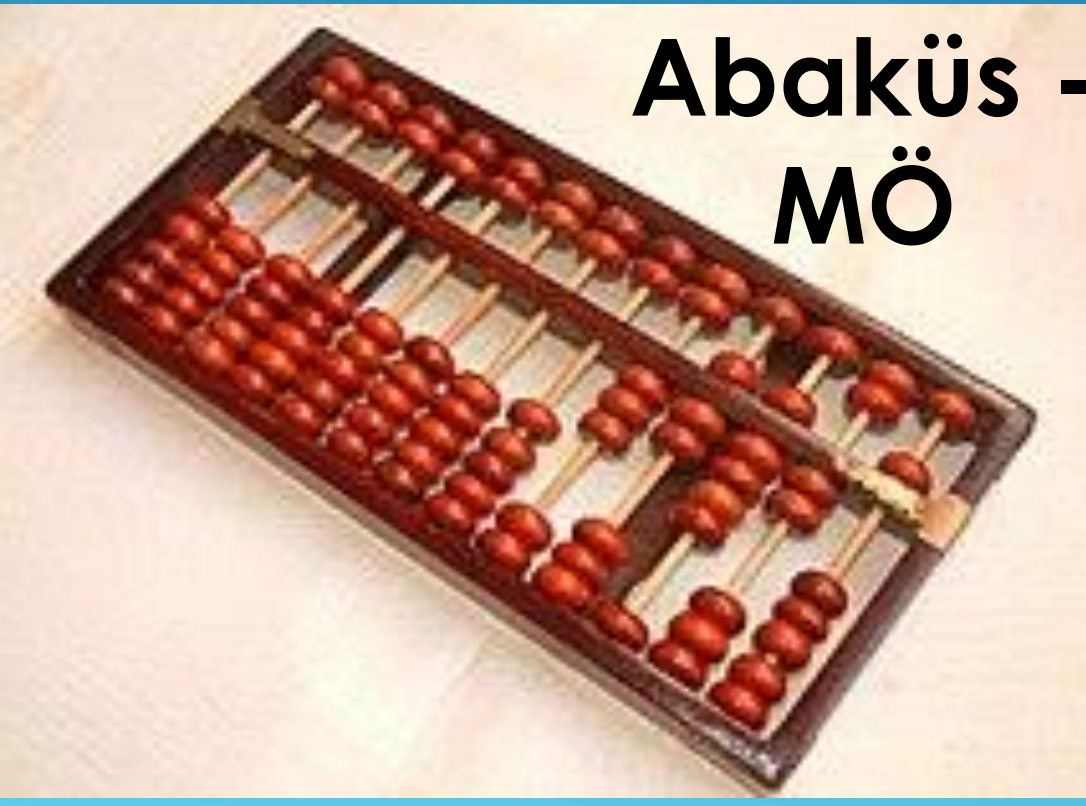

Abaküs - MÖ

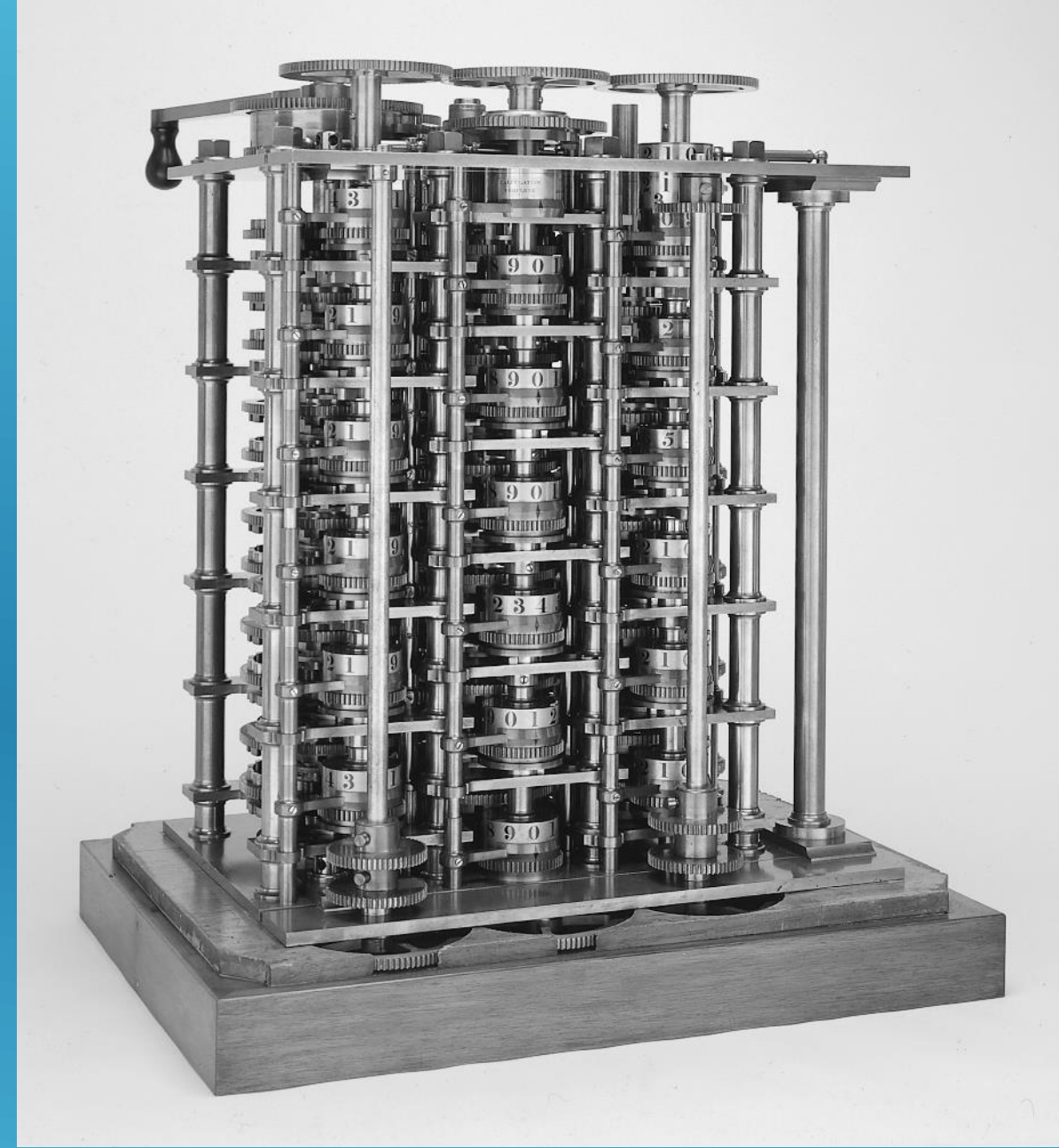

The Babbage Fark Motoru - 1832

Yakın Geçmişte



Mekanik Hesap Makinesi (FACIT) - 1900

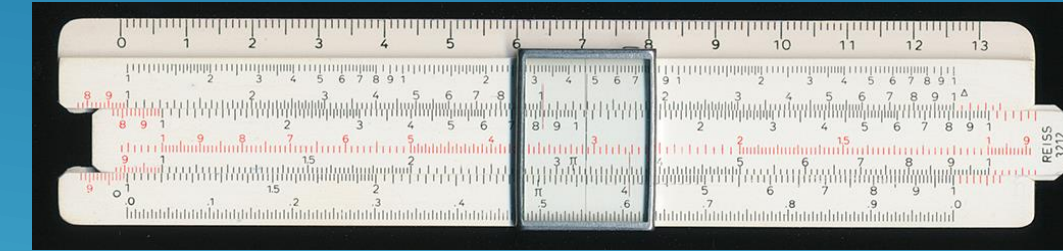

Hesap Cetveli - 1600

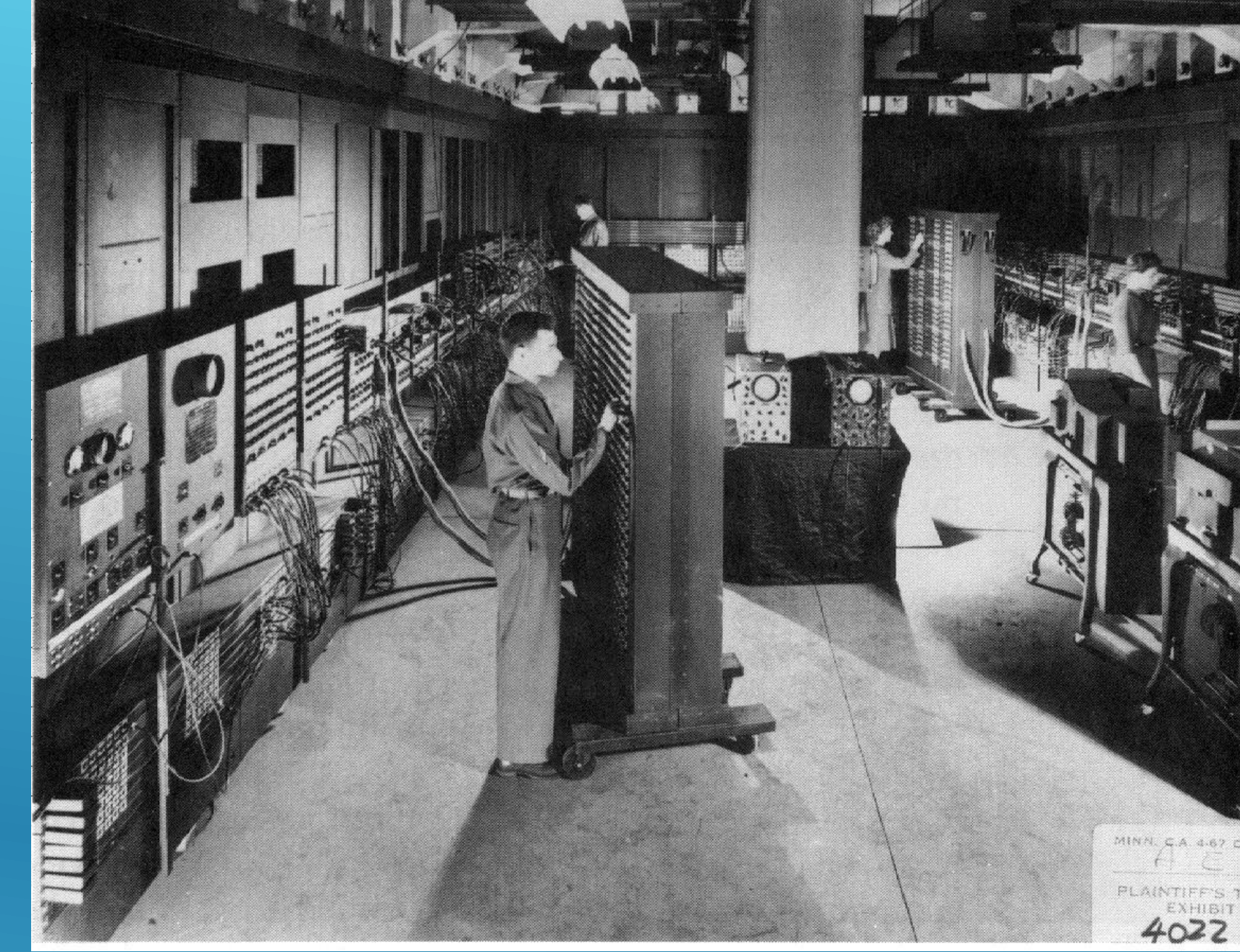

Oda Büyüklüğünde Elektronik Bilgisayar (ENIAC) - 1946

Günümüz ☺

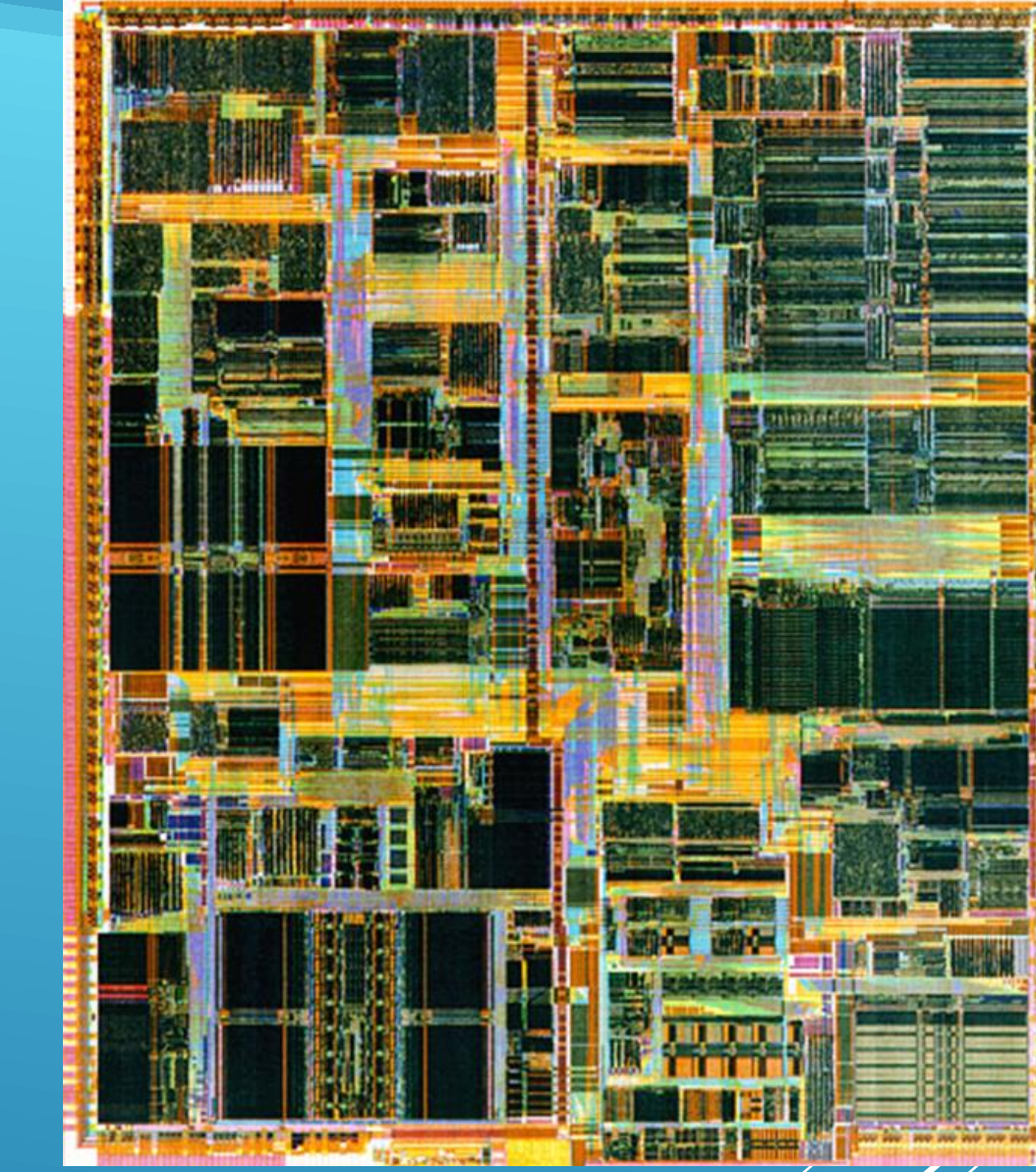

Intel Pentium 4 - 2000
42 milyon transistör
2.2 cm²



Intel Core i9 - 2017
4 milyar transistör
2.4 cm²

Elektronik Hesaplamanın Temeli: Mantık İkili Sayı Tabanı - Bitler

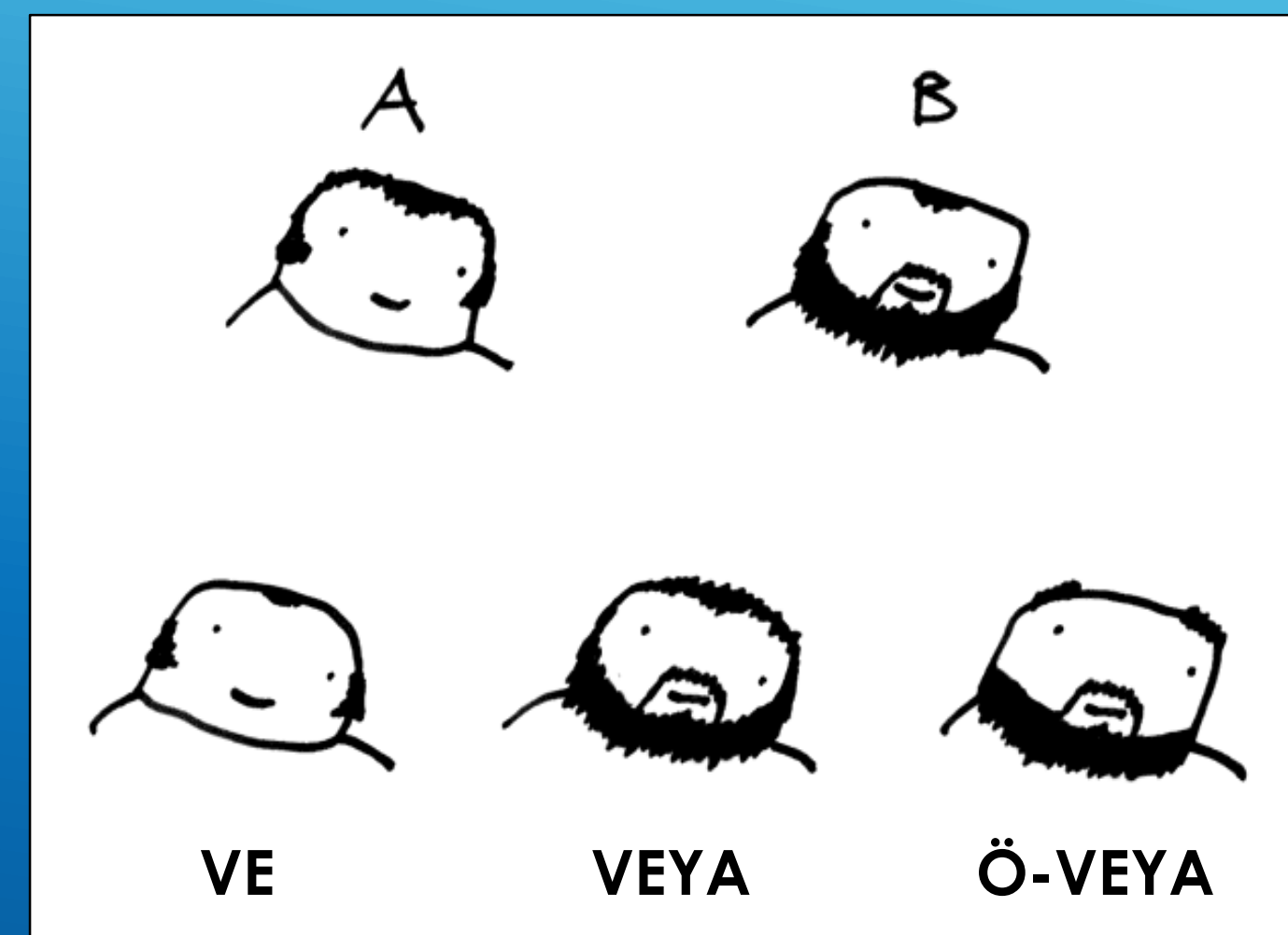
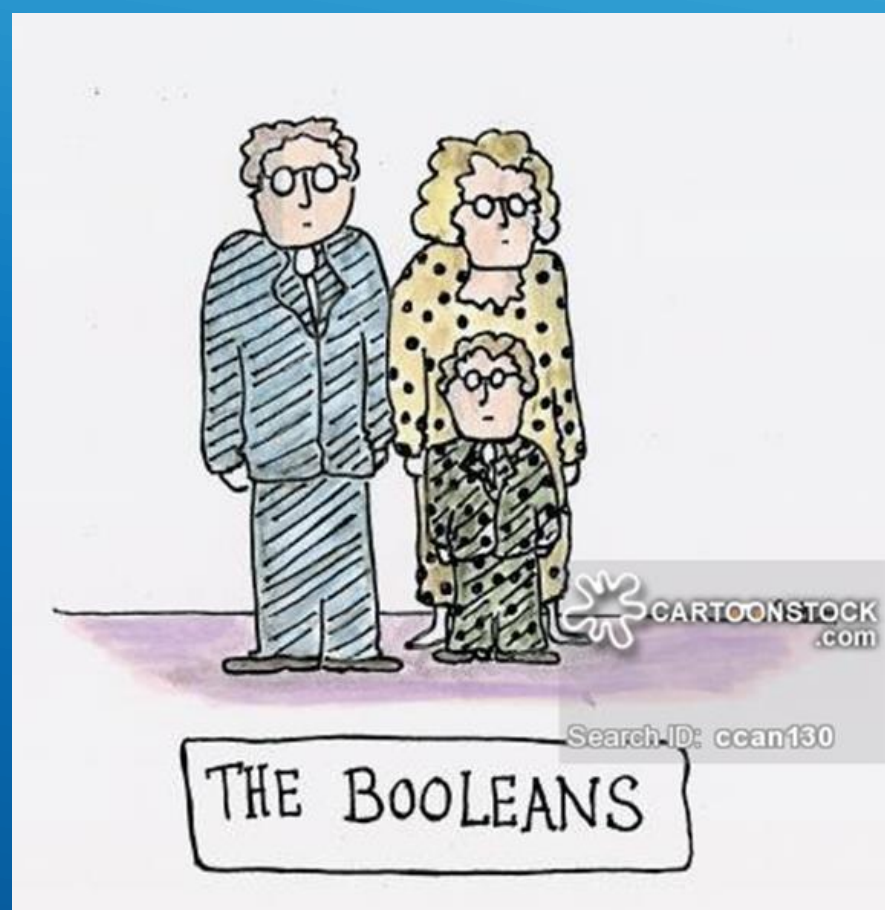

$$\begin{array}{r} 2 \\ + 5 \\ \hline 7 \end{array} \quad \begin{array}{r} 010 \\ + 101 \\ \hline 111 \end{array}$$

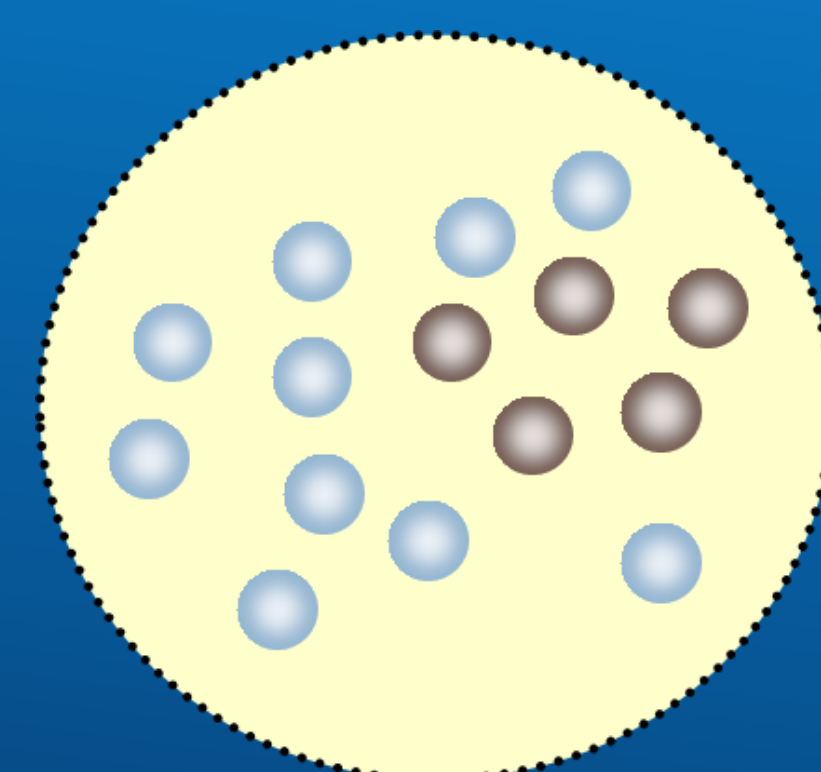
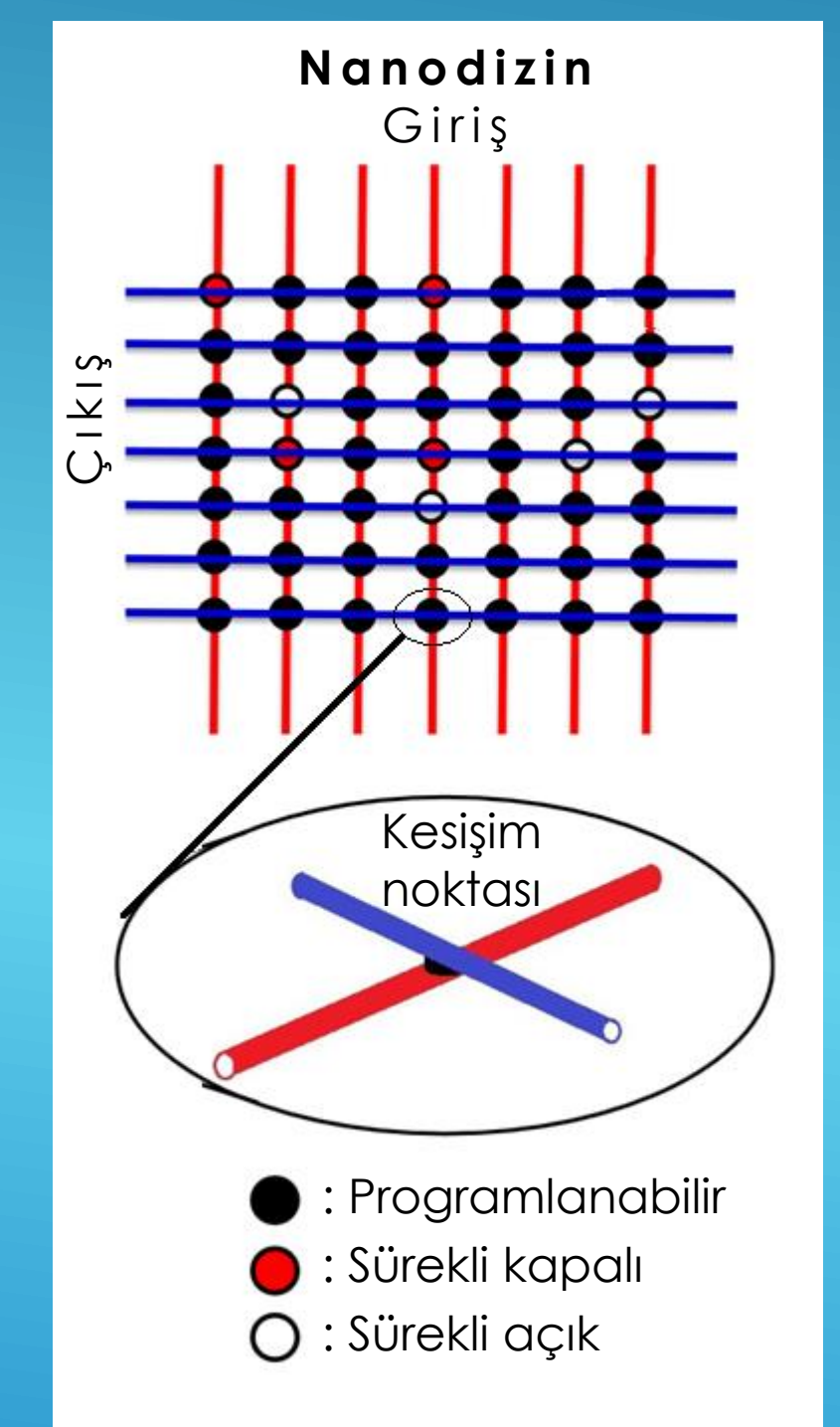
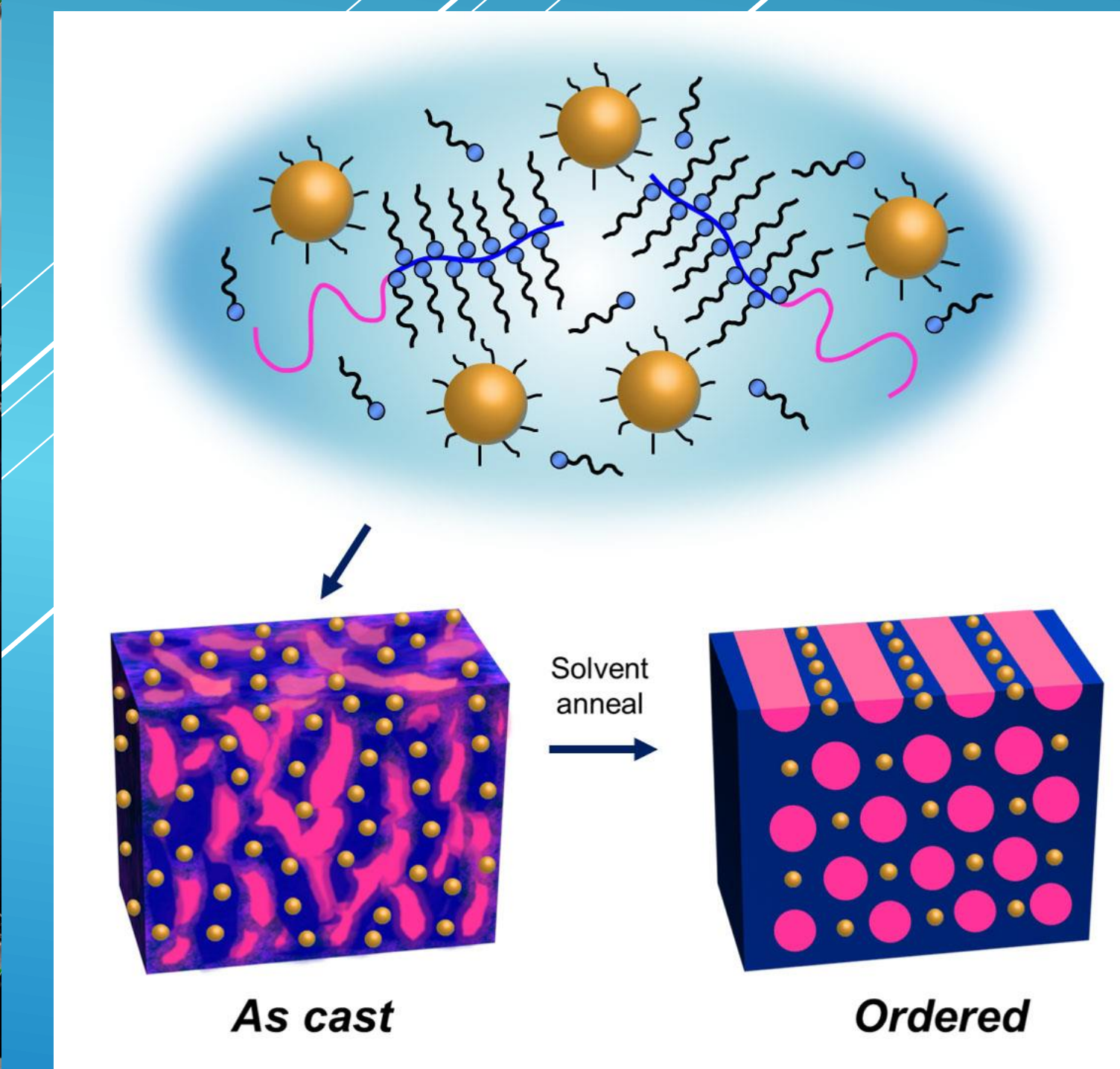
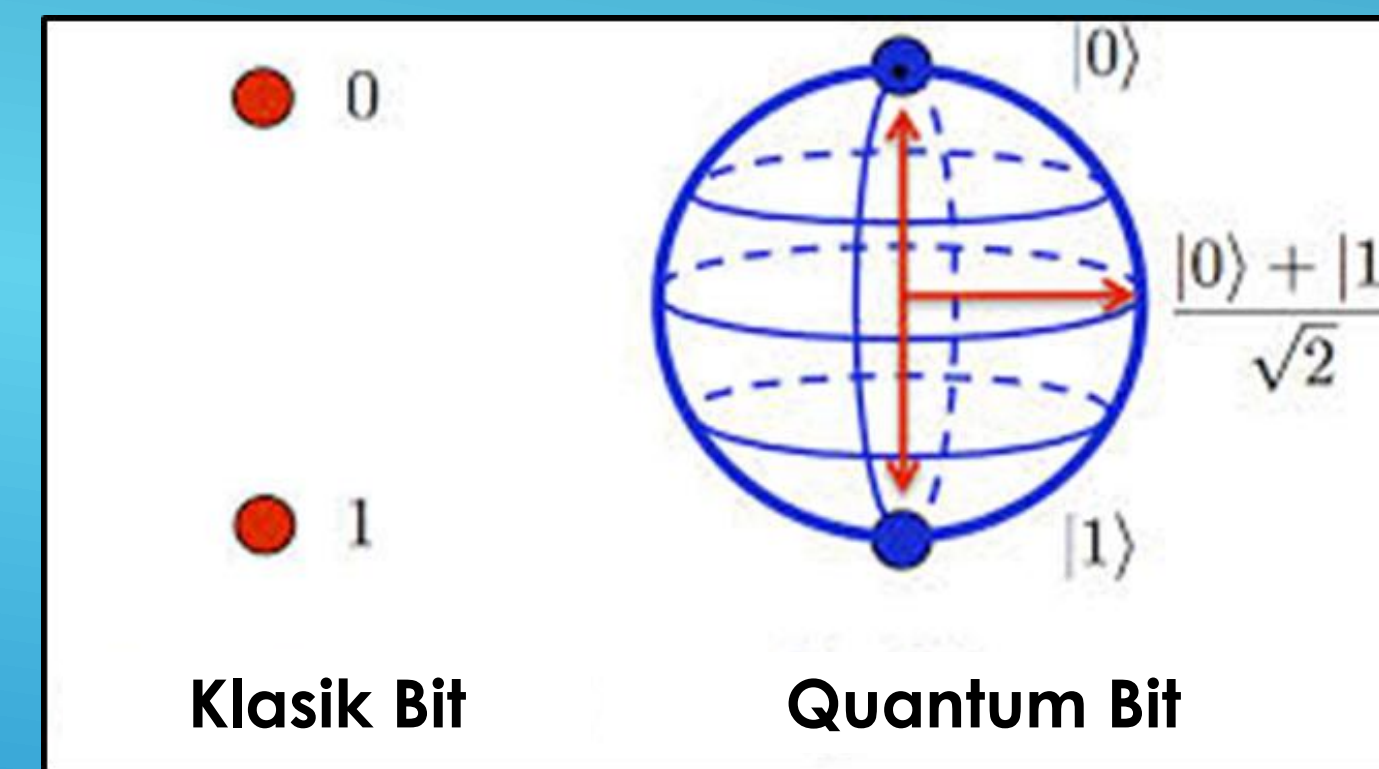
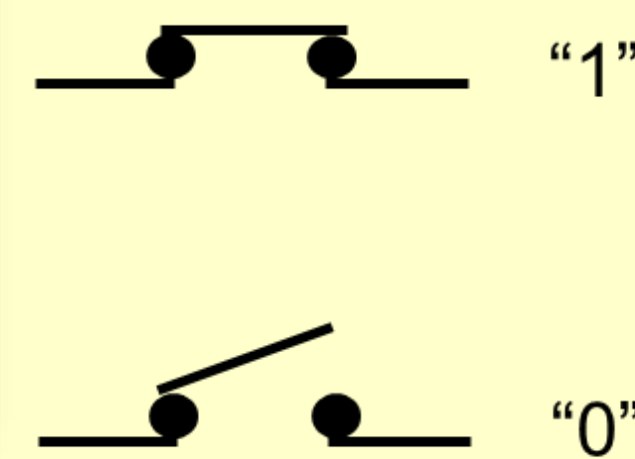
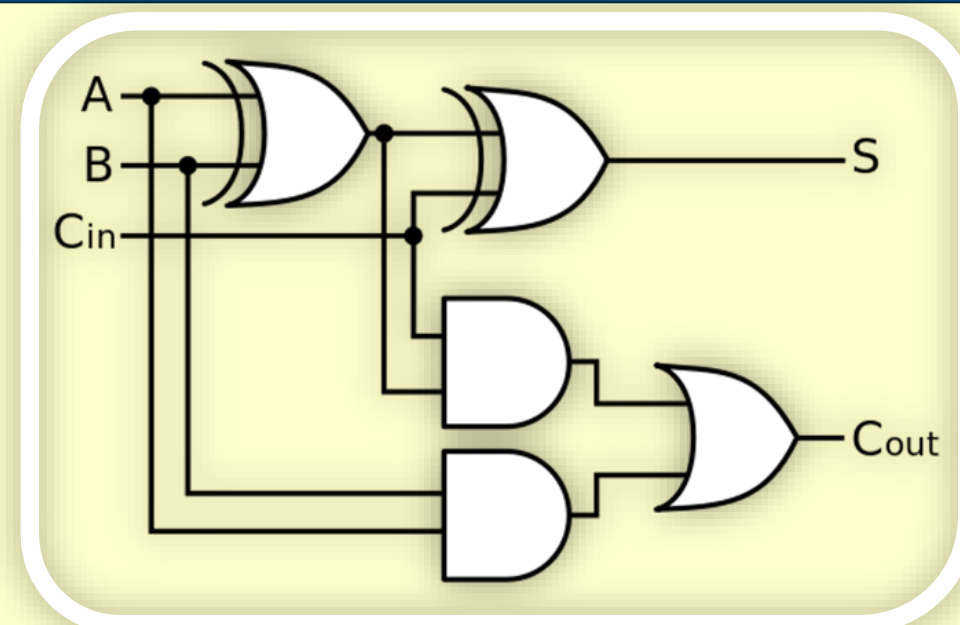

10 Mavi 5 Siyah

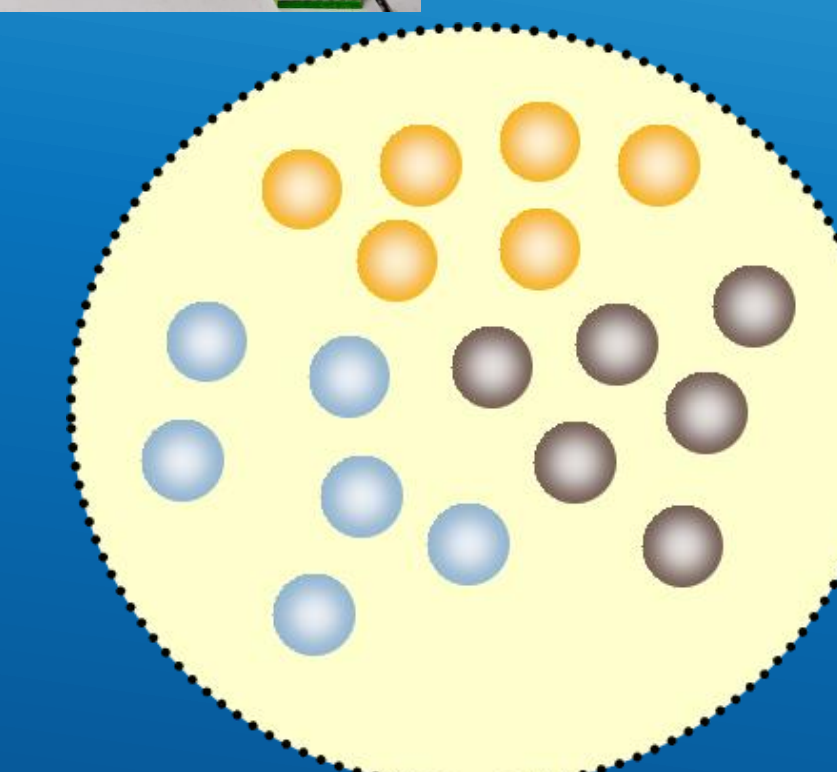
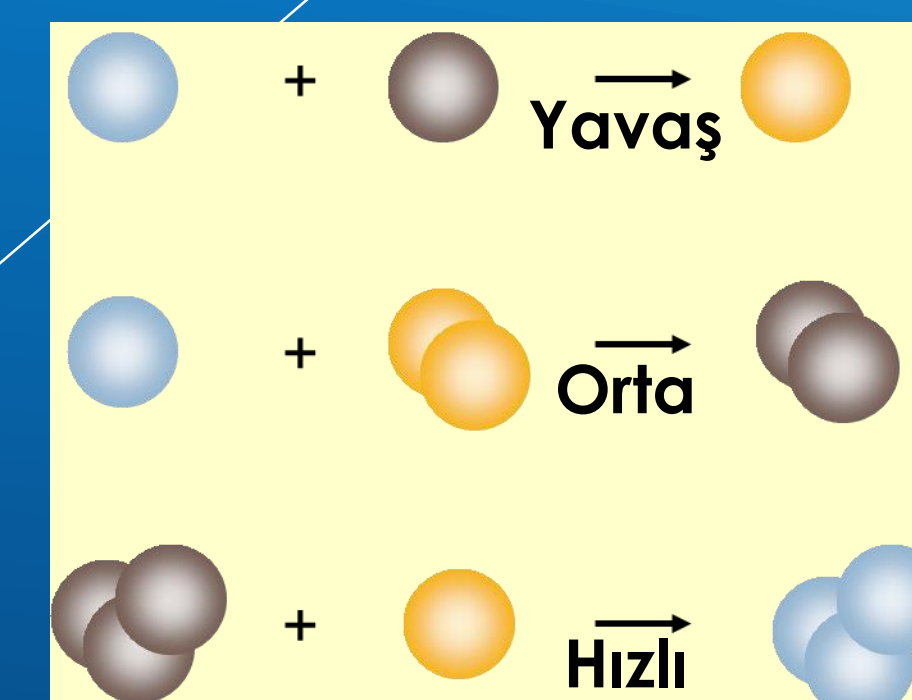

6 Mavi 6 Siyah 6 Sarı

